

Cold

Custom Counter

Your deli products look **DELicious** in our full serve or self serve Cold model. This model has been designed for presentation of packed and unpacked products that are not prone to dehydration such as cheese, meat-products and meals.

In the spotlight

Warm white or optional meat-enhancing LED light makes your products look bright and fresh! Your chilled products enjoy optimal product temperatures thanks to superior refrigeration technology. The Cold model has the highest stacking height in our range.

Custom Counter Configurator

Designing a tailor-made counter is easier than ever before with our Custom Counter Configurator. The Fri-Jado team is ready to assist you in configuring your perfect counter by using this tool. The configurator creates a counter that meets your exact needs and visualizes what this could look like in a 3D image.



Key Features Custom Counter Cold

- Curved or Unisquare (squared) lift-up glass
- OmniCold refrigeration system: products are surrounded by a cold airflow from all sides, guaranteeing optimal product temperatures under all conditions whilst saving energy
- LED light (cool white / neutral white / warm white / extra warm white / meat enhancing)
- Optional blackened stainless steel interior
- Optional front lighting
- Flat deck, stepped deck or GN pans interior
- Large customizable worktop (280 mm) with optional accessory rail to mount cutting boards, sliding scale platforms, bag hooks etc.
- Various bumper options
- Customizable cladding and materials
- Integral or remote refrigeration
- Optional night covers
- Modular and connectable with other Custom Counter models



Lift-up glass opens in its own space



LED light



Customizable cladding and materials

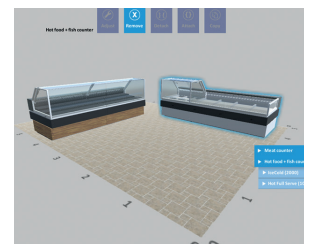

Custom Counter Configurator

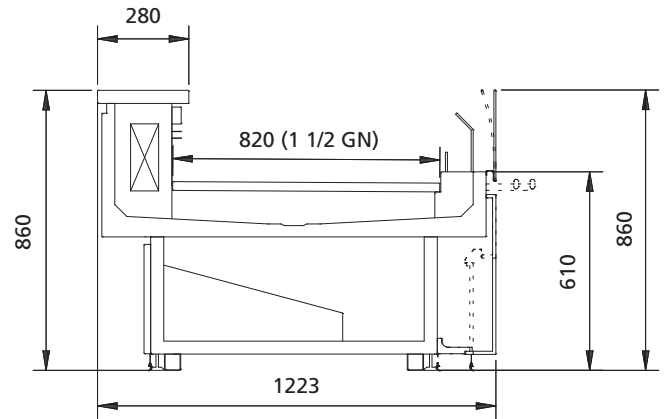
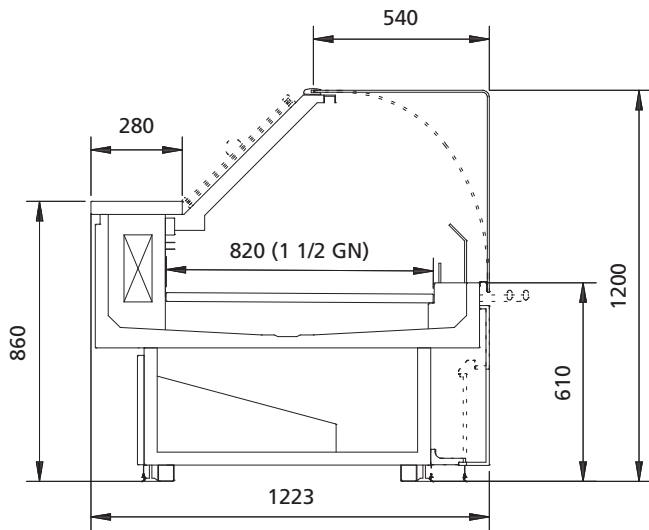

Technical specifications

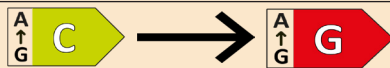
Model	Cold full serve, self serve	
Length options (mm)	750, 1000, 1250, 1500, 1750, 2000, 2250, 2500, 2750, 3000, 3250, 3500, 3750*	
Nominal voltage	1N~230V 50/60Hz	
Product temperature	up to 3M0 (-1 < T < 4 °C) according to EN ISO 23953**	
Presentation area depth	820 mm or 1 ½ GN	
Refrigeration load	50-150 W/m***	
Refrigeration capacity	< 400 W/m	
Evaporation temperature	Up to - 4°C	
Stacking height - standard interior	Up to 200 mm at 0M0	
Stacking height - lowered interior	Up to 250 mm at 0M0	
Glass	Curved or Unisquare (squared) lift-up glass	
Lighting	LED cool white / neutral white / warm white / extra warm white / meat enhancing	
Technology	OmniCold: mild airflow, rear evaporator coil, chilled deck	
Refrigerant options (other refrigerants on request)	Remote	R744 (CO ₂), R513A, R448A, R449A, R452A, R407F, R404A****, R507A****, Glycol
	Integral	R1234yf, R134a
Energy class EU Energy Efficiency Index (EEI)		
Interior configuration	Flat deck, stepped deck, GN pans	
Interior material	Stainless steel AISI 304 (optional blackened)	
Exterior	Customizable cladding and materials. Various bumper options.	

* Minimum and/or maximum length may be limited by selected refrigeration options.

** Depending on store temperature, interior configuration, stacking height and evaporation temperature.

*** REC at 0M0 conditions, 24 hour average. Effective REC depends on store conditions, product load and cabinet configuration.

**** No longer allowed in the EU

Specifications and technical data are subject to amendment without prior notice. Please check www.frijado.com for the latest information and specifications. The energy class declared here is based on standard product configurations, individual or customized units may differ. For more information please refer to the energy label provided with each cabinet or contact a Fri-Jado sales office