

# FreshCold

Custom Counter

Your products need to be fresh, look fresh and stay fresh. The FreshCold full serve model has been designed for presentation of fresh unpacked products such as fresh meat. Optional meat-enhancing LED light and an optional blackened stainless steel interior make your products look delicious.

## The dehydration challenge

Dehydration is a common thing when presenting fresh unpacked products such as fresh meat. Dehydration means weight loss, and weight loss means reduced profits. Our optional ultrasonic misting system reduces weight loss to only 1% per day! This means prolonged freshness and extended shelf life, resulting in less waste and more profit.

## Custom Counter Configurator

Designing a tailor-made counter is easier than ever before with our Custom Counter Configurator. The Fri-Jado team is ready to assist you in configuring your perfect counter by using this tool. The configurator creates a counter that meets your exact needs and visualizes what this could look like in a 3D image.



## Features Custom Counter FreshCold

- Curved or Unisquare (squared) lift-up glass
- OmniCold refrigeration system: products are surrounded by a cold airflow from all sides, guaranteeing optimal product temperatures under all conditions whilst saving energy
- LED light (cool white / neutral white / warm white / extra warm white / meat enhancing)
- Optional humidification system with ultrasonic misting
- Optional blackened stainless steel interior
- Optional front lighting
- Flat deck, stepped deck or GN pans interior
- Large customizable worktop (280 mm) with optional accessory rail to mount cutting boards, sliding scale platforms, bag hooks etc.
- Various bumper options
- Customizable cladding and materials
- Integral or remote refrigeration
- Optional night covers
- Modular and connectable with other Custom Counter models



Optional ultrasonic misting



Lift-up glass opens in its own space



Customizable cladding and materials

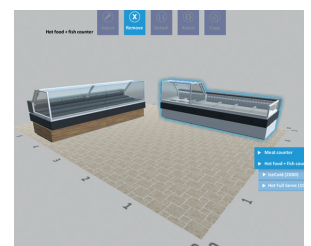

Custom Counter Configurator

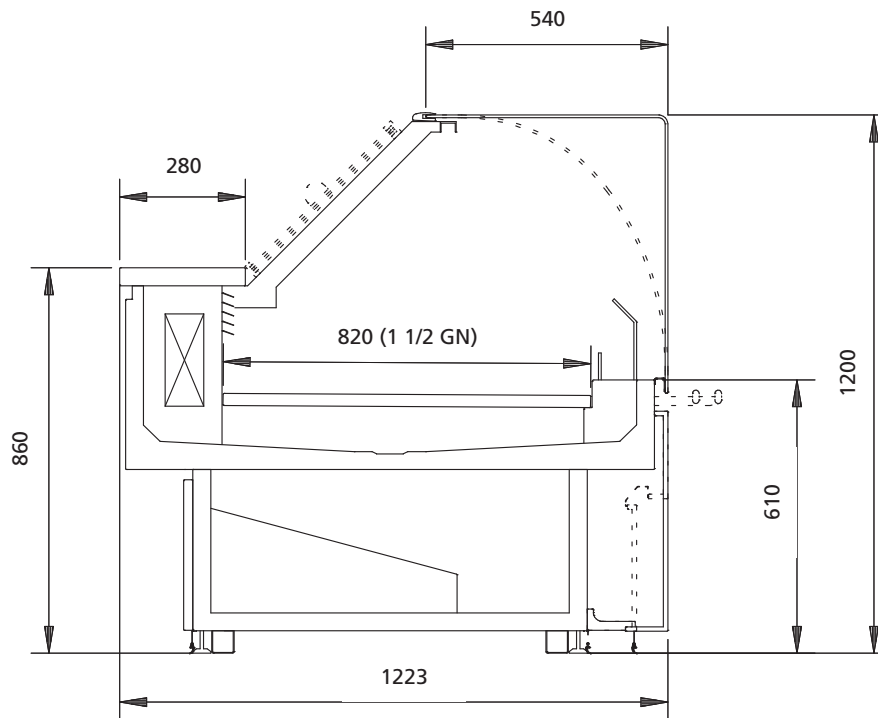

### Technical specifications

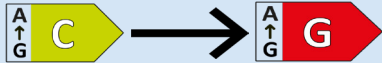
Model	FreshCold full serve
Length options (mm)	750, 1000, 1250, 1500, 1750, 2000, 2250, 2500, 2750, 3000, 3250, 3500, 3750*
Nominal voltage	1N~230V 50/60Hz
Product temperature	up to 3M0 (-1 < T < 4 °C) according to EN ISO 23953**
Presentation area depth	820 mm or 1 ½ GN
Refrigeration load	50-150 W/m***
Refrigeration capacity	< 400 W/m
Evaporation temperature	Up to - 4 °C
Stacking height - standard interior	Up to 180 mm at 0M0
Stacking height - lowered interior	Up to 230 mm at 0M0
Glass	Curved or Unisquare (squared) lift-up glass
Lighting	LED cool white / neutral white / warm white / extra warm white / meat enhancing
Technology	OmniCold: mild airflow, rear evaporator coil, chilled deck
Humidification system	Ultrasonic misting (optional)
Refrigerant options (other refrigerants on request)	Remote R744 (CO <sub>2</sub> ), R513A, R448A, R449A, R452A, R407F, R404A****, R507A****, Glycol Integral R134a, R1234yf
Energy class EU Energy Efficiency Index (EEI)	 A → G
Interior configuration	Flat deck, stepped deck, GN pans
Interior material	Stainless steel AISI 304 (optional blackened)
Exterior	Customizable cladding and materials. Various bumper options.

\* Minimum and/or maximum length may be limited by selected refrigeration and misting options.

\*\* Depending on store temperature, interior configuration, stacking height and evaporation temperature.

\*\*\* REC at 0M0 conditions, 24 hour average. Effective REC depends on store conditions, product load and cabinet configuration.

\*\*\*\* No longer allowed in the EU

Specifications and technical data are subject to amendment without prior notice. Please check [www.frijado.com](http://www.frijado.com) for the latest information and specifications. The energy class declared here is based on standard product configurations, individual or customized units may differ. For more information please refer to the energy label provided with each cabinet or contact a Fri-Jado sales office