

# Hot

## Custom Counter



Think of ready-to-eat hot products that can even be consumed in store. The Hot model ensures that your products maintain a core temperature of  $>65^{\circ}\text{C}$  for over 5 hours. Hot airflow technology and optional humidification prevents dehydration.

### Hot vs. Cold

Present your hot and cold products side by side by integrating our Hot full Serve model with any cold model in the same design. The only thing that separates hot from cold is a piece of insulated glass that minimizes heat transfer.

### Custom Counter Configurator

Designing a tailor-made counter is easier than ever before with our Custom Counter Configurator. The Fri-Jado team is ready to assist you in configuring your perfect counter by using this tool. The configurator creates a counter that meets your exact needs and visualizes what this could look like in a 3D image.



### Key features Custom Counter Hot

- Curved or Unisquare (squared) lift-up glass
- Heat lamp
- Hot airflow technology
- Optional humidification
- Optional blackened stainless steel interior
- Flat/tilted deck or flat/tilted GN pans interior
- Large customizable worktop (280 mm) with optional accessory rail to mount cutting boards, sliding scale platforms, bag hooks etc.
- Various bumper options
- Customizable cladding and materials
- Modular and connectable with other Custom Counter models



Hot & Cold in one integrated design



Lift-up glass opens in its own space



Customizable cladding and materials

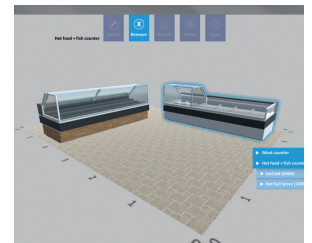

Custom Counter Configurator

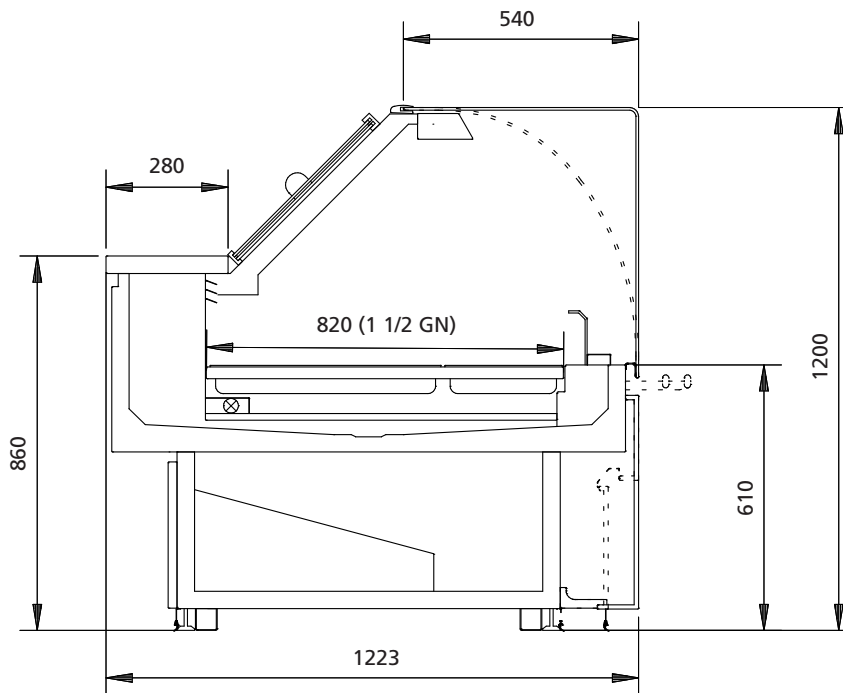

### Technical specifications

Model	Hot - full serve
Length options (mm)	750, 1000, 1250, 1500, 1750, 2000, 2250, 2500, 2750, 3000
Nominal voltage	3N~ 400/230V 50/60Hz
Product temperature	65 < T < 70 °C
Presentation area depth	820 mm or 1 ½ GN
Glass	Curved or Unisquare (squared) lift-up glass
Lighting	Quartz-halogen lamp
Technology	Forced air convection, radiant heat lamp
Humidification system	Hot humidified (optional)
Interior configuration	Flat deck, tilted deck, GN pans
Interior material	Stainless steel AISI 304 (optional blackened)
Exterior	Customizable cladding and materials. Various bumper options.
Worktop	Large customizable worktop (280 mm) with optional accessory rail to mount cutting boards, sliding scale platforms, bag hooks etc.

Specifications and technical data are subject to amendment without prior notice.

Please check [www.frijado.com](http://www.frijado.com) for the latest information and specifications.