

# In-store impulse-generating merchandiser

Multi Deck 60 - 4 level  
Premium square



**The Fri-Jado Multi Deck boosts hot food-to-go sales with an irresistible product presentation. It can be used anywhere in the store to stimulate customers to pick up hot grab-and-go products. Thanks to its square, upright design, it lines up smoothly with other equipment and uses only limited floor space.**

Our patented Hot Blanket holding technology controls food safety. Hot air is blown from the front of the shelf and circulates over the shelf surface, after which it is recycled into the unit. Your products are completely surrounded by a blanket of hot air, ensuring an even holding temperature.

Large, transparent side panels provide a 180-degree view on your products. The appealing design provides an outstanding product presentation which is sure to boost impulse sales.

## Features MD 60 - 4 Premium square

### Top features

- Square design - square glass, black canopy
- Interchangeable price strips on each shelf
- Hot Blanket holding technology - keeps products warm at 65° for at least 4 hours
- Endless possibilities - ideal for chicken (portions), panini, pies, pastries, soups, hot rolls, wraps etc.

### Standard characteristics

- Self serve heated Multi Deck display unit
- 60 cm wide - 4 level display
- Total presentation area of 1.04 m<sup>2</sup>
- Footprint of 0.48 m<sup>2</sup>
- Solid back
- Angled shelves provide optimum product visibility
- Shatter-resistant clear side glass for optimum safety
- Front bumpers to protect from shopping carts
- Saves up to 20% on energy by air-curtain technology on each shelf
- 98% recyclable (environmentally friendly)
- Plug-and-play

### Accessories

- Customer-side temperature indicator
- Shelf leveler



Optimum product visibility



Stylish black canopy



Square glass

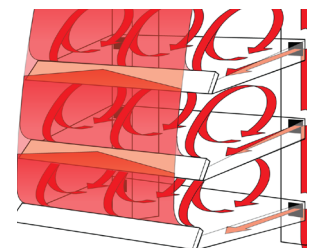

Keeps hot food at 65°C

## MD 60-4 Premium square

1 Power cable, 2.5 m

### Dimensions

Width	600 mm
Depth	790 mm
Height	1972 mm

### Technical data

Net weight	190 kg
Gross weight	246 kg
Voltage	1N~ 230 V
Frequency	50/60 Hz
Power	3 kW

Specifications and technical data are subject to amendment without notice

These are basic drawings. For more detailed technical information, please refer to the installation manual at [www.frijado.com](http://www.frijado.com).

Patent number: EP2309897

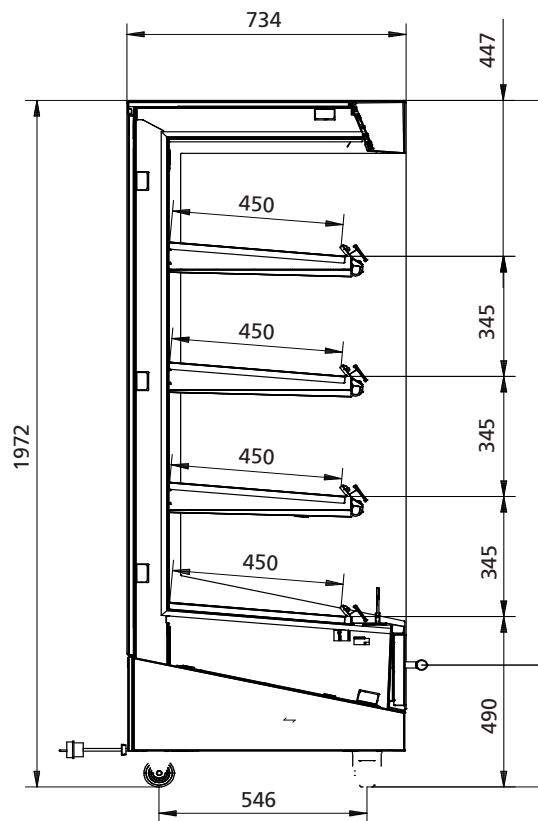
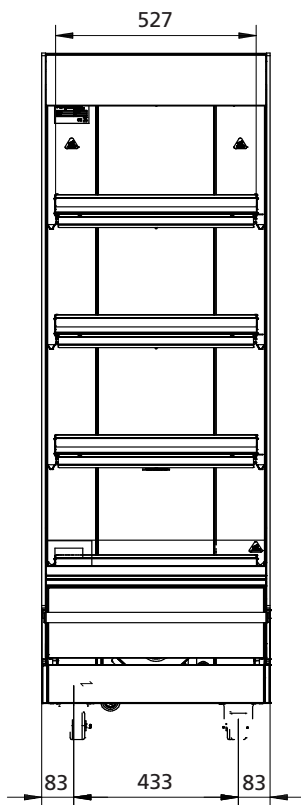
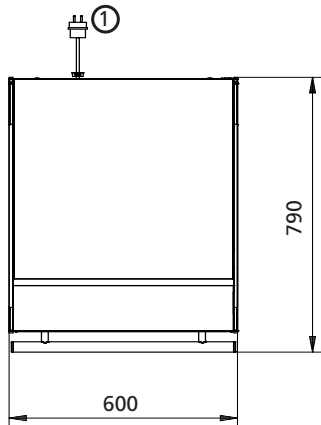

# In-store impulse-generating merchandiser

Multi Deck 100 - 4 level  
Premium square



**The Fri-Jado Multi Deck boosts hot food-to-go sales with an irresistible product presentation. It can be used anywhere in the store to stimulate customers to pick up hot grab-and-go products. Thanks to its square, upright design, it lines up smoothly with other equipment and uses only limited floor space.**

Our patented Hot Blanket holding technology controls food safety. Hot air is blown from the front of the shelf and circulates over the shelf surface, after which it is recycled into the unit. Your products are completely surrounded by a blanket of hot air, ensuring an even holding temperature.

Large, transparent side panels provide a 180-degree view on your products. The appealing design provides an outstanding product presentation which is sure to boost impulse sales.

## Features MD 100 - 4 Premium square

### Top features

- Square design - square glass, black canopy
- Interchangeable price strips on each shelf
- Hot Blanket holding technology - keeps products warm at 65° for at least 4 hours
- Endless possibilities - ideal for chicken (portions), panini, pies, pastries, soups, hot rolls, wraps etc.

### Standard characteristics

- Self serve heated Multi Deck display unit
- 100 cm wide - 4 level display
- Total presentation area of 1.76 m<sup>2</sup>
- Footprint of 0.8 m<sup>2</sup>
- Solid back
- Angled shelves provide optimum product visibility
- Shatter-resistant clear side glass for optimum safety
- Front bumpers to protect from shopping carts
- Saves up to 20% on energy by air-curtain technology on each shelf
- 98% recyclable (environmentally friendly)
- Plug-and-play

### Accessories

- Customer-side temperature indicator
- Shelf leveler



Optimum product visibility



Stylish black canopy



Square glass

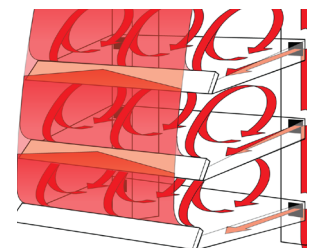

Keeps hot food at 65°C

## MD 100-4 Premium square

1 Power cable, 2.5 m

### Dimensions

Width	1000 mm
Depth	790 mm
Height	1972 mm

### Technical data

Net weight	235 kg
Gross weight	322 kg
Voltage	3N~ 400/230 V
Frequency	50/60 Hz
Power	4.5 kW

Specifications and technical data are subject to amendment without notice.

These are basic drawings. For more detailed technical information, please refer to the installation manual at [www.frijado.com](http://www.frijado.com).

Patent number: EP2309897

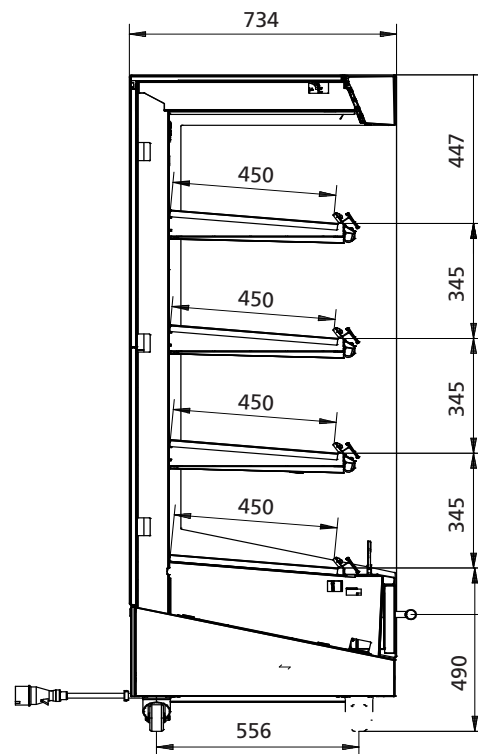
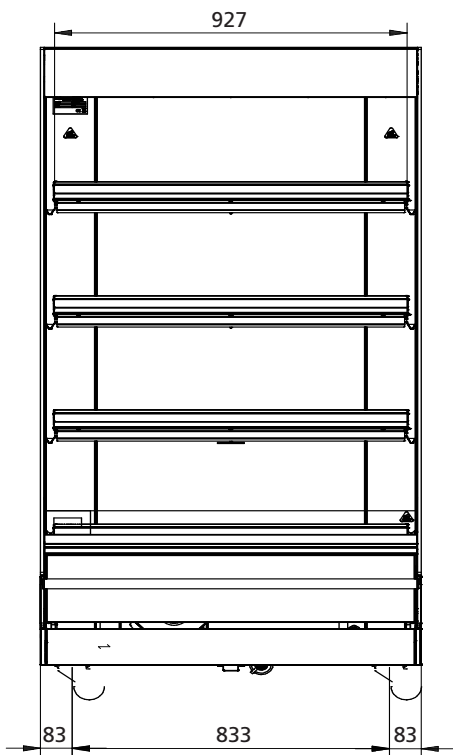
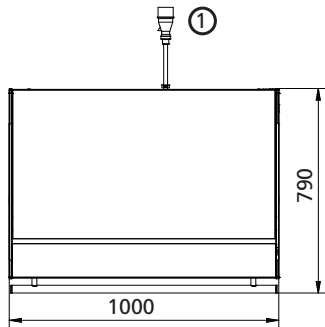

# In-store impulse-generating merchandiser

Multi Deck 120 - 4 level  
Premium square



**The Fri-Jado Multi Deck boosts hot food-to-go sales with an irresistible product presentation. It can be used anywhere in the store to stimulate customers to pick up hot grab-and-go products. Thanks to its square, upright design, it lines up smoothly with other equipment and uses only limited floor space.**

Our patented Hot Blanket holding technology controls food safety. Hot air is blown from the front of the shelf and circulates over the shelf surface, after which it is recycled into the unit. Your products are completely surrounded by a blanket of hot air, ensuring an even holding temperature.

Large, transparent side panels provide a 180-degree view on your products. The appealing design provides an outstanding product presentation which is sure to boost impulse sales.

## Features MD 120 - 4 Premium square

### Top features

- Square design - square glass, black canopy
- Interchangeable price strips on each shelf
- Hot Blanket holding technology - keeps products warm at 65° for at least 4 hours
- Endless possibilities - ideal for chicken (portions), panini, pies, pastries, soups, hot rolls, wraps etc.

### Standard characteristics

- Self serve heated Multi Deck display unit
- 120 cm wide - 4 level display
- Total presentation area of 2.12 m<sup>2</sup>
- Footprint of 0.96 m<sup>2</sup>
- Solid back
- Angled shelves provide optimum product visibility
- Shatter-resistant clear side glass for optimum safety
- Front bumpers to protect from shopping carts
- Saves up to 20% on energy by air-curtain technology on each shelf
- 98% recyclable (environmentally friendly)
- Plug-and-play

### Accessories

- Customer-side temperature indicator
- Shelf leveler



Optimum product visibility



Stylish black canopy

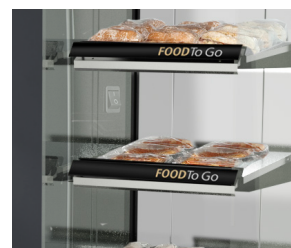

Square glass

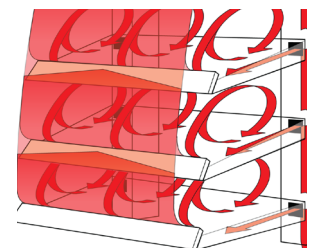

Keeps hot food at 65°C

## MD 120-4 Premium square

1 Power cable, 2.5 m

### Dimensions

Width	1200 mm
Depth	790 mm
Height	1972 mm

### Technical data

Net weight	250 kg
Gross weight	290 kg
Voltage	3N~ 400/230 V
Frequency	50/60 Hz
Power	5.4 kW

Specifications and technical data are subject to amendment without notice.

These are basic drawings. For more detailed technical information, please refer to the installation manual at [www.frijado.com](http://www.frijado.com).

Patent number: EP2309897

