

In-store impulse-generating merchandiser

Multi Deck 60 - 5 level



Selling hot food from a self serve merchandiser is a great way to increase your sales and margins. The Fri-Jado heated Multi Deck triggers your customers to pick up hot grab-and-go products in a quick and convenient way, anywhere in the store. And thanks to its upright design, it only uses limited floor space.

Hot air is blown from the front of the shelf and circulates within the shelf surface resulting in optimum air circulation around the hot product.

Large glazed walls give a 180-degree view of the products. The appealing design gives outstanding product presentation which is sure to boost impulse sales.

Features MD 60-5 Premium

Top features

- Self serve heated Multi Deck display
- Attractive presentation that boosts impulse sales
- Patented Hot Blanket holding technology keeps products warm
- Customizable price strips
- Illuminated, customizable top banner
- Safety lighting on each level

Standard characteristics

- 60 cm wide - 5 level display
- Product temperature maintained at 65°C
- Ideal for chicken, wraps, snacks, soups etc.
- Upright design saves space
- Total display capacity of 1.3 m²
- Footprint of 0.5 m²
- Shatter-resistant clear side glass for optimum safety
- Saves up to 20% on energy by air-curtain technology on each shelf
- Safe holding temperature for up to four hours
- Angled shelves provide optimum product visibility
- Front bumpers to protect from shopping carts
- Solid back as standard
- 98% recyclable (environmentally friendly)
- Plug-and-play

Accessories

- Customer-side temperature indicator
- Lower skirts (covering wheels)

Optional

- Doors at rear (pass through)
- Front door



Optimum product visibility



Signage



Rear doors (optional)

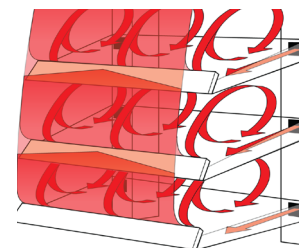

Keeps hot food at 65°C

MD 60-5 Premium

1 Power cable, 2,5 m

Dimensions

Width	600 mm
Depth	800 mm
Height	1972 mm

Technical data

Net weight	209 kg
Gross weight	246 kg
Voltage	3N~ 400/230 V
Frequency	50/60 Hz
Power	3.6 kW

Specifications and technical data are subject to amendment without notice.

These are basic drawings. For more detailed technical information, please refer to the installation manual at www.frijado.com.

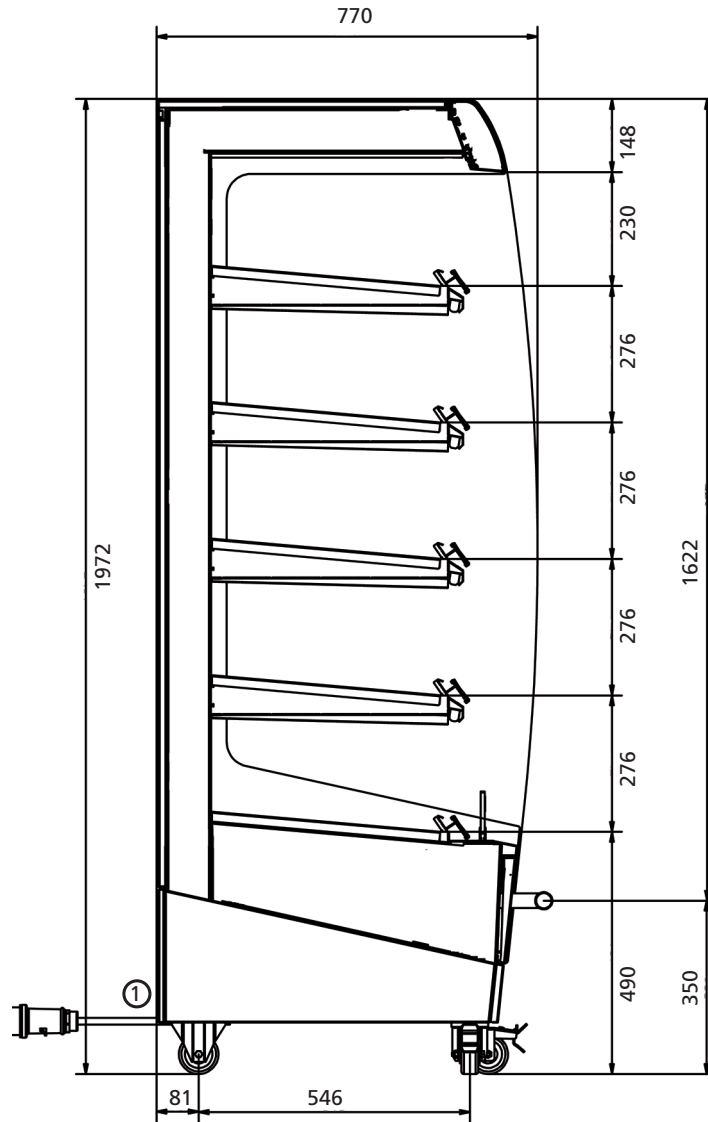
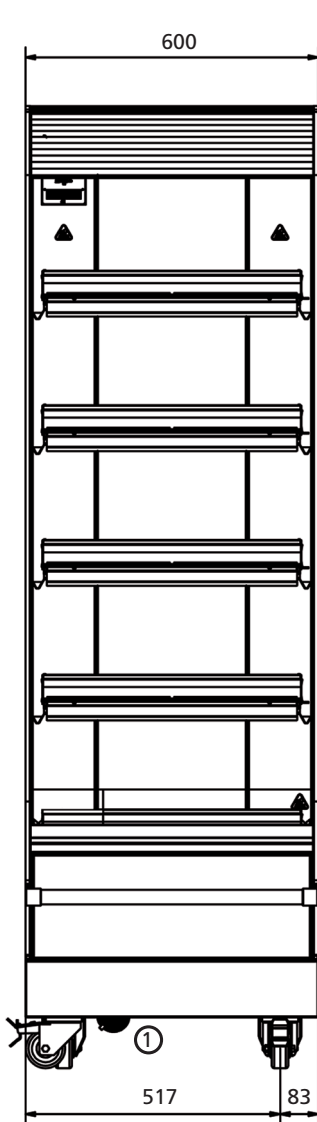
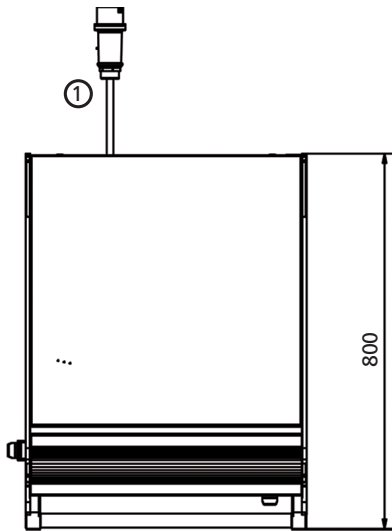

In-store impulse-generating merchandiser

Multi Deck 100 - 5 level



Selling hot food from a self serve merchandiser is a great way to increase your sales and margins. The Fri-Jado heated Multi Deck triggers your customers to pick up hot grab-and-go products in a quick and convenient way, anywhere in the store. And thanks to its upright design, it only uses limited floor space.

Hot air is blown from the front of the shelf and circulates within the shelf surface resulting in optimum air circulation around the hot product.

Large glazed walls give a 180-degree view of the products. The appealing design gives outstanding product presentation which is sure to boost impulse sales.

Features MD 100 - 5 Premium

Top features

- Self serve heated Multi Deck display
- Attractive presentation that boosts impulse sales
- Patented Hot Blanket holding technology keeps products warm
- Customizable price strips
- Illuminated, customizable top banner
- Safety lighting on each level

Standard characteristics

- 100 cm wide - 5 level display
- Product temperature maintained at 65°C
- Ideal for chicken, wraps, snacks, soups etc.
- Upright design saves space
- Total display capacity of 2.2 m²
- Footprint of 0.8 m²
- Shatter-resistant clear side glass for optimum safety
- Saves up to 20% on energy by air-curtain technology on each shelf
- Safe holding temperature for up to four hours
- Angled shelves provide optimum product visibility
- Front bumpers to protect from shopping carts
- Solid back as standard
- 98% recyclable (environmentally friendly)
- Plug-and-play

Accessories

- Customer-side temperature indicator
- Lower skirts (covering wheels)

Optional

- Doors at rear (pass through)
- Front doors



Optimum product visibility



Signage



Rear doors (optional)

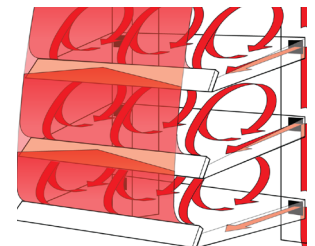

Keeps hot food at 65°C

MD 100-5 Premium

1 Power cable, 2 m

Dimensions

Width	1000 mm
Depth	800 mm
Height	1972 mm

Technical data

Net weight	274 kg
Gross weight	322 kg
Voltage	3N~ 400/230 V
Frequency	50/60 Hz
Power	5.4 kW

Specifications and technical data are subject to amendment without notice.

These are basic drawings. For more detailed technical information, please refer to the installation manual at www.frijado.com.

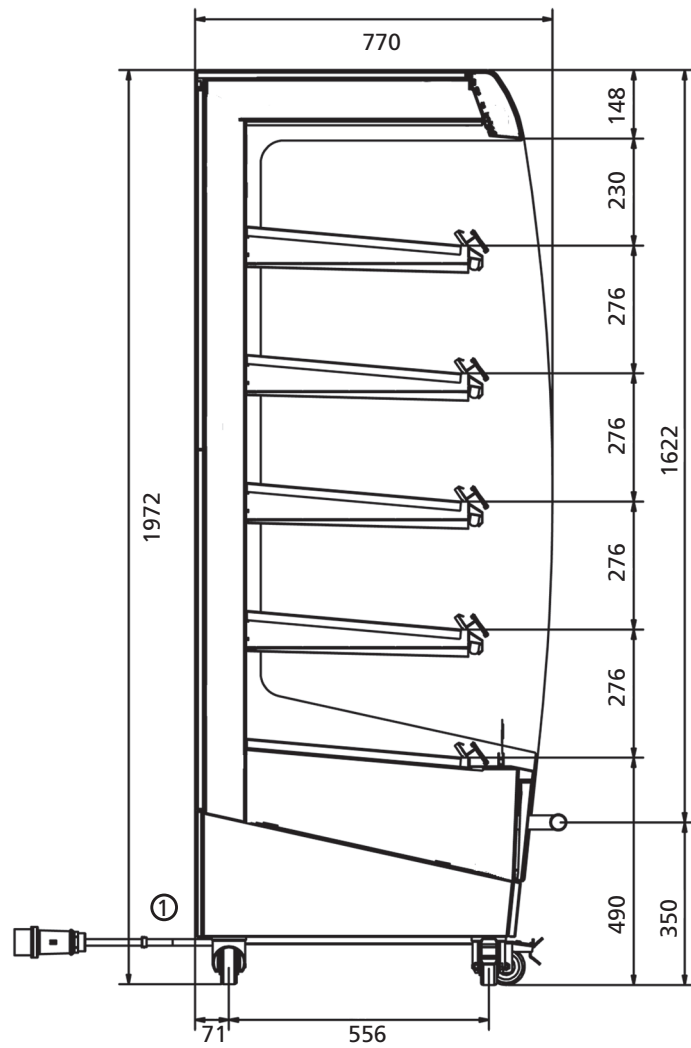
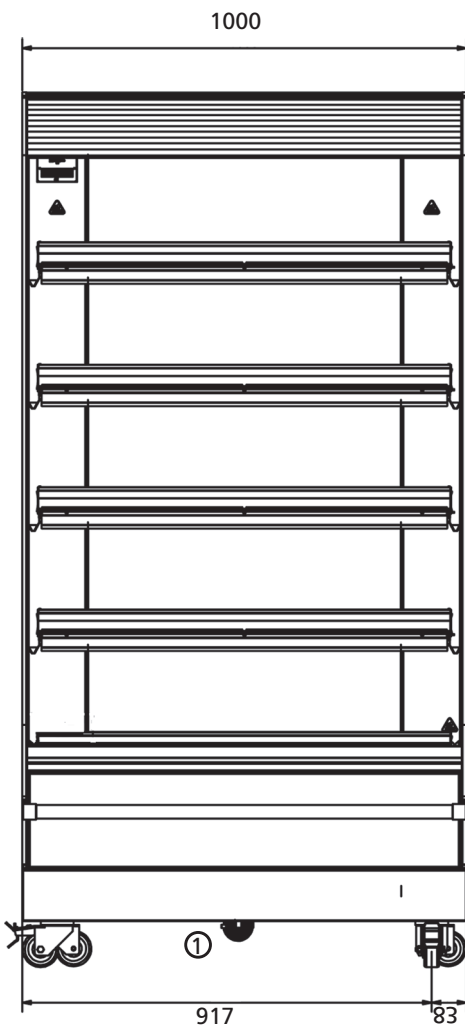
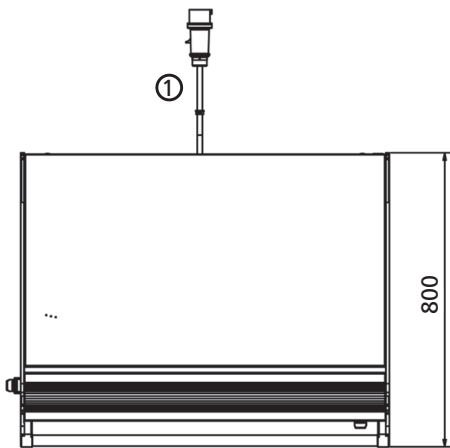

In-store impulse-generating merchandiser

Multi Deck 120 - 5 level



Selling hot food from a self serve merchandiser is a great way to increase your sales and margins. The Fri-Jado heated Multi Deck triggers your customers to pick up hot grab-and-go products in a quick and convenient way, anywhere in the store. And thanks to its upright design, it only uses limited floor space.

Hot air is blown from the front of the shelf and circulates within the shelf surface resulting in optimum air circulation around the hot product.

Large glazed walls give a 180-degree view of the products. The appealing design gives outstanding product presentation which is sure to boost impulse sales.

Features MD 120-5 Premium

Top features

- Self serve heated Multi Deck display
- Attractive presentation that boosts impulse sales
- Patented Hot Blanket holding technology keeps products warm
- Customizable price strips
- Illuminated, customizable top banner
- Safety lighting on each level

Standard characteristics

- 120 cm wide - 5 level display
- Product temperature maintained at 65°C
- Ideal for chicken, wraps, snacks, soups etc.
- Upright design saves space
- Total display capacity of 2.7 m²
- Footprint of 1 m²
- Shatter-resistant clear side glass for optimum safety and insulation
- Saves up to 20% on energy by air-curtain technology on each shelf
- Safe holding temperature for up to four hours
- Angled shelves provide optimum product visibility
- Front bumpers to protect from shopping carts
- Solid back as standard
- 98% recyclable (environmentally friendly)
- Plug-and-play

Accessories

- Customer-side temperature indicator
- Lower skirts (covering wheels)

Optional

- Doors at rear (pass through)
- Front doors



Optimum product visibility



Signage



Rear doors (optional)

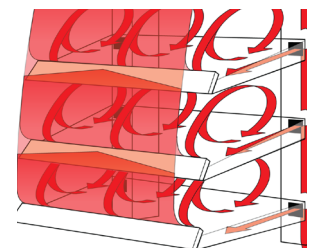

Keeps hot food at 65°C

MD 120-5 Premium

1 Power cable, 2 m

Dimensions

Width	1200 mm
Depth	800 mm
Height	1972 mm

Technical data

Net weight	300 kg
Gross weight	353 kg
Voltage	3N~ 400/230 V
Frequency	50/60 Hz
Power	6.5 kW

Specifications and technical data are subject to amendment without notice.

These are basic drawings. For more detailed technical information, please refer to the installation manual at www.frijado.com.

