

A revolution in cooking and merchandising

Multisserie with disposable waste bags



The Multisserie is a revolution in visual cooking and merchandising. Designed to give extra prominence to your products, the Multisserie allows your customers a 270-degree view of the cooking theatre.

The Multisserie cooks up to 50% faster than conventional ovens and rotisseries! Load up to 72 kg of poultry or any other meat products. The combination of steam and convection prepares the meat deliciously. The Multisserie is fast, reliable and gives consistent results.

With the fully automatic cleaning system, cleaning can be done overnight without operator intervention. The Multisserie with grease collector comes with an integrated system that collects grease and other liquid waste in disposable bags during the cook cycle.

Features Multisserie with disposable waste bags

Top features

- Collection of grease and other liquid waste in disposable bags
- Fully automatic cleaning system with detergent and rinse aid dispenser
- Intelligent controls - easy, consistent operation
- Cook Correction detects and corrects abnormalities during the cook cycle
- Endless possibilities: poultry (parts), pork roast, ribs, lamb, roast beef, pork belly, meat loaf, porchetta and other proteins

Standard characteristics

- Supplied on stand
- 12 Chicken racks for up to 60 chickens (1,2 kg)
- 250 programs with up to 9 steps
- Boiler-less steam generator with different steam levels, programmable
- Multi-purpose baskets available for preparation of chicken parts, ribs, etc.

Accessories

- Chicken racks (included)
- Multi-purpose baskets
- Door locking handle on customer side
- Water filtration system

Optional

- Internal condenser
- Stainless steel cladding for underframe

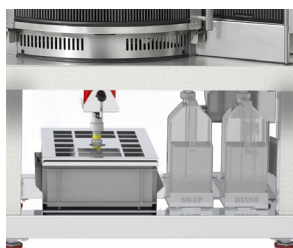

Hygienic fat collection



Internal condenser (optional)

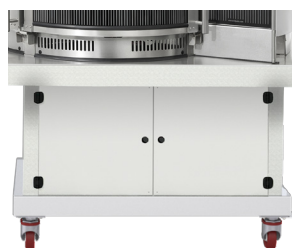

Stainless steel cladding (optional)



Fully automatic cleaning

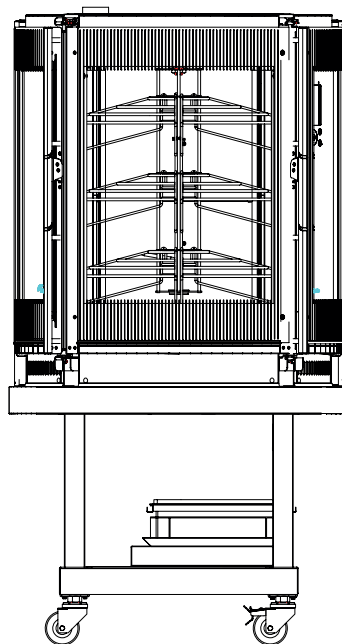
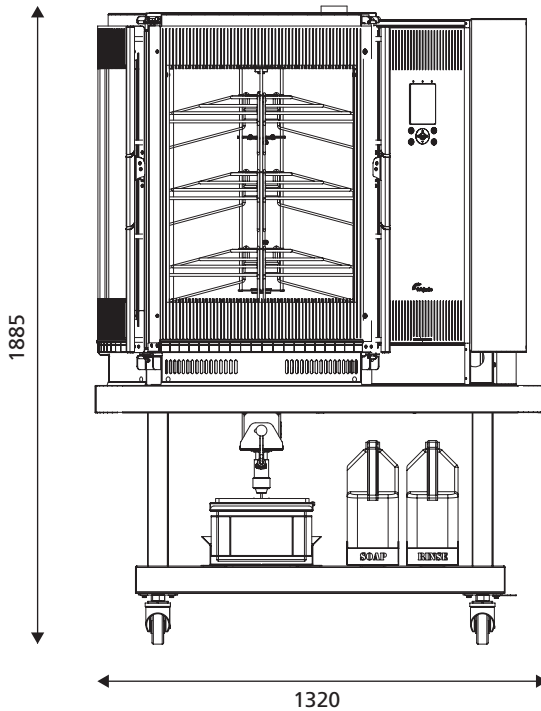
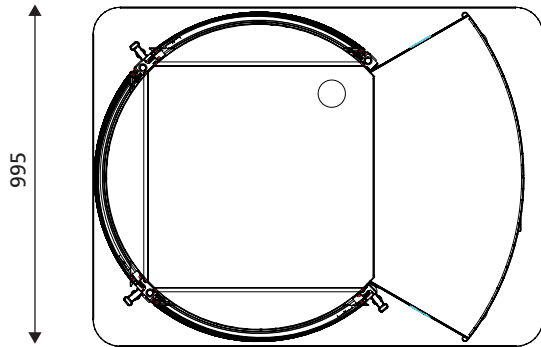

Multiserie with disposable waste bags

Dimensions

Width	995 mm
Depth	1320 mm
Height	1885 mm

Technical data

Net weight	360 kg
Gross weight	475 kg
Voltage	3N~ 400/230 V
Frequency	50 Hz
Power	21 kW
Breaker	32/55 A
Temperature range	20-250°C
Water drain	50 mm
Water connection Wash	G ¾ "
Water connection Steam&Rinse	G ¾ "
Water pressure	min. 40 psi at 4 GPM

Specifications and technical data are subject to amendment without notice.

These are basic drawings. For more detailed technical information, please refer to the installation manual at www.frijado.com.