



ICE MAKERS

IQ 300 / 500 / 900 / 1300 / 2700 Flake Series



Drier Type Ice



Daily Ice Production	IQ 300	IQ 500	IQ 900	IQ 1300	IQ 2700
	360 Lbs./ 163 kg.	675 Lbs./ 306 kg.	980 Lbs. / 445 kg.	1430 Lbs. / 649 kg.	2860 Lbs. / 1298 kg.

Standard Features

FLAKE ICE: Humidity 50-60%. The best ice for so many applications.



SEAFOOD: Supermarkets, Fisheries, Fish Shops, Seafood Restaurants, Boating, Marinas.



HEALTHCARE & RESEARCH: Hospitals, Laboratories, Universities.



SPORTS: Football, Basketball, Baseball, Athletics, Swimming, Soccer, Track & Field, Traumas, Pre and Post Training, Spas, Sports Medical Facilities.
Rest + Ice + Compression + Elevation First Aid Method.



DRINKS: Soft drinks, Smoothies. I love to chew my ITV's flake ice!



STRONG MECHANICS: ITV's unique mechanic design is simple, strong and reliable. It will give a longer life to your flaker, and shorten service times and costs. Oversized gearbox. Patented Auger design for greater longevity of the ice maker.



SECURITY CONTROLS: The machine is protected to avoid failures caused by gearbox motor temperature, water level, or ice level, besides a defrost time delay.



ELECTROMECHANICAL CONTROLS: The machine works with electromechanical timer and thermostats. Simple, easy to comprehend and service. High reliability and low maintenance expense.



EASY ACCESS FOR SERVICE AND INSTALLATION: Designed to have better access to all components making installation and servicing operations easier. One person can disassemble the entire machine with a basic screwdriver.



OPERATING LIMITS: Tropicalized machines (Class T); Suitable for low temperature environments of 41° (5°C) Air and Water and high temperature environments of 109°F (43°C) (Air), 95°F (35°C) (Water) Water pressure: Min. 10 psi. (0.7 bar.)/ Max. 85 psi. (6 bar.).
NOTE: Install a pressure reducer if water inlet pressure is more than 85 psi. (6 bar.).



ELECTRICAL SPECIFICATIONS: **IQ 300 & IQ 500** :115V/60Hz./1 - Fuse Size 15-20 - Nema Plug Type 5-15P. Also available 220V/50Hz (Special order only).
IQ 900 & IQ 1300 208-230V/60Hz/ 1 or 3. **IQ 2700** 208-230V/60Hz/3.



WARRANTY: 24 months parts and labor + 12 additional months parts on compressor + 36 additional months parts on Auger. Valid in the U.S. and Canada. Contact ITV for warranty in other countries.

ICE QUEEN 300 / 500 / 900 / 1300 / 2700 MODULAR FLAKE ICE MACHINES



ICE MAKERS

IQ 300 / 500 / 900 / 1300 / 2700 Flake Series



Dimensions (Inch./Cm.)

IQ	W	D	H
IQ 300	20 1/4" / 52 cm.	21 6/8" / 55 cm.	19 1/8" / 49 cm.
IQ 500			22 3/4" / 58 cm.
IQ 900	26 5/8" / 68 cm.		26 3/8" / 67 cm.
IQ 1300			31 1/2" / 80 cm.
IQ 2700	52 5/8" / 134 cm.	24" / 61 cm.	32 1/8" / 82 cm.

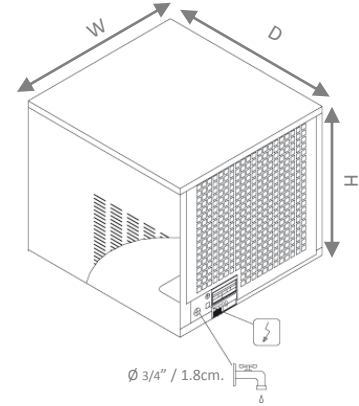

General Specifications

IQ SERIES	Production				Suggested Bin	Water Usage gal./hr. / l. / hr. 90°F/70°F	Voltage	Amps.	R404A oz.	Net Weight Lbs./ Kg.	Filtration Kit
	70°F Air/50°F Water		90°F Air/70°F Water								
	Lbs./ 24 h.	Kg./ 24 h.	Lbs./ 24 h.	Kg./ 24 h.							
10114 IQ 300 A	360	163	260	118	S-430 IQ	1.8 / 6.8	115V/60Hz/1	7	12.36	108/49	CS-111 K
10115 IQ 300 W	365	166	265	120	S-430 IQ		115V/60Hz/1	6.5	13.41	108/49	
10124 IQ 500 A	675	306	485	220	S-430 IQ	3.4/12.8	115V/60Hz/1	9	15.89	115/52	CS-102 K
10125 IQ 500 W	685	311	495	225	S-430 IQ		115V/60Hz/1	8.5	15.53	115/52	
10132 IQ 900 A	980	445	710	322	S-1030 IQ	4.9/18.5	208-230V/60Hz/1	9.5	56.48	181/82	CS-112 K
10133 IQ 900 W	1005	456	730	331	S-1030 IQ		208-230V/60Hz/1	9	52.95	181/82	
10142 IQ 900 A III	980	445	710	322	S-1030 IQ	4.9/18.5	208-230V/60Hz/3	6	56.48	181/82	CS-112 K
10143 IQ 900 W III	1005	456	730	331	S-1030 IQ		208-230V/60Hz/3	5.5	52.95	181/82	
10154 IQ 1300 A	1430	649	1030	467	S-1030 IQ	7.1/27.0	208-230V/60Hz/1	12.5	52.95	231/105	CS-112 K
10155 IQ 1300 W	1450	658	1050	476	S-1030 IQ		208-230V/60Hz/1	11.5	56.48	231/105	
10162 IQ 1300 A III	1430	649	1030	467	S-1030 IQ	7.1/27.0	208-230V/60Hz/3	7.5	52.95	231/105	CS-112 K
10163 IQ 1300 W III	1450	658	1050	476	S-1030 IQ		208-230V/60Hz/3	7	56.48	231/105	
10172 IQ 2700 A	2860	1298	2060	935	S-1030 IQ	14.3/54.1	208-230V/60Hz/3	15	2*56.5	463/210	CS-112 K
10173 IQ 2700 W	2900	1316	2100	953	S-1030 IQ		208-230V/60Hz/3	14	2*53	463/210	

A: Air—Cooled / W: Water—Cooled/ Due to our continuous efforts for improving and developing our range of products, ITV Ice Makers, Inc. reserves the right of changing features with no previous notice. •Water cooled units available special order only, restrictions may apply. Please contact your dealer for details.

Shipping Weight: IQ 300: 121.3 Lbs. (55 Kg.) / IQ 500: 132.3 Lbs. (62 Kg.) / IQ 900: 251.3 Lbs. (114 Kg.) / IQ 1300: 284 Lbs. (130 Kg.) / IQ 2700: 573.2 Lbs. (260 Kg.)

Ice Shape



"Fine" Style Ice Flakes



ICE QUEEN Flakes



ISO 9001:2008
CERTIFICATION

© 2013 ITV Ice Makers, Inc